

Bimetal Thermometers

OEM Dial Bimetal Thermometers

REOTEMP OEM Thermometers (Models Q, G, and H) are the perfect choice for equipment with limited space and requiring a rugged, dependable and economical temperature sensor. Available with a wide variety of mounting threads.

Model Q - 1 5/32" Dial

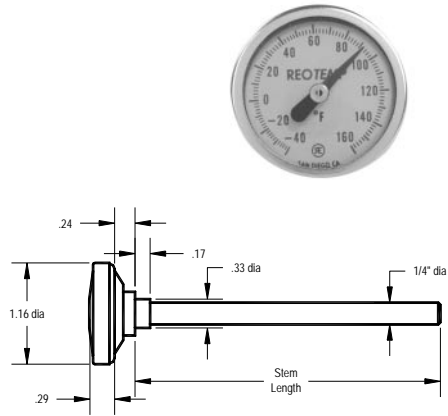

Model G - 1 11/16" Dial

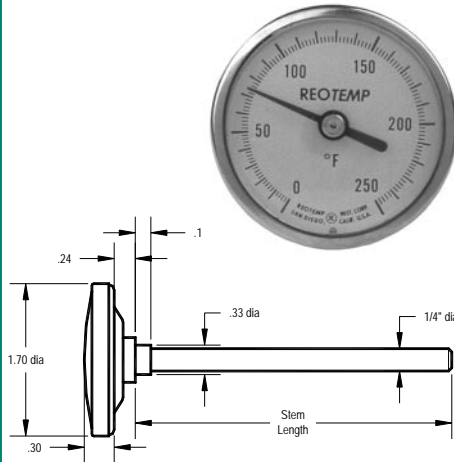

Model H - 2 3/8" Dial

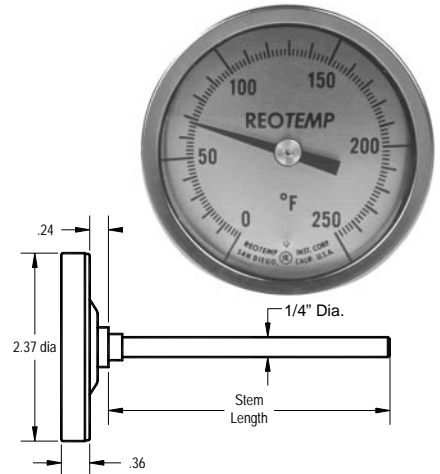

Mounting Thread Options

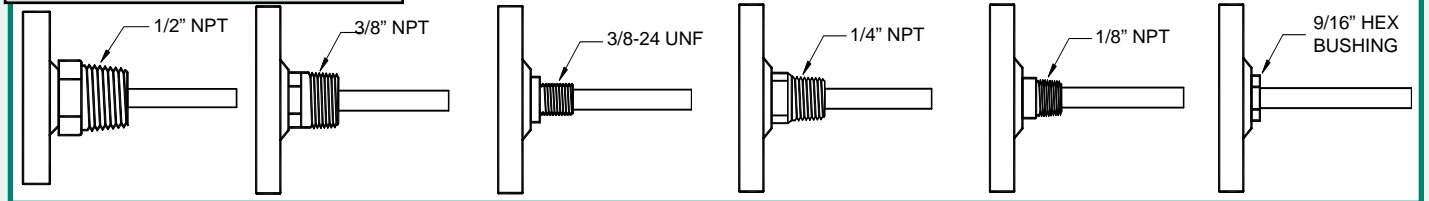

How to Order

QQ — **025** — **2** — **F43** — **PS**

Models	Stem Length	Connection	Temperature Ranges <small>(See pg. 13 for full list)</small>	Options
OEM Models			Fahrenheit Ranges	
QQ = Model Q (1-1/4" dial)	025 = 2.5"	2 = Plain Bushing (std.)	F23 -40 TO 160°F	PS = Pointed Stem
	040 = 4"	1 = 1/2" NPT	F55* 25 TO 125°F	SS = 316 SS Stem
GG = Model G (1-3/4" dial)	060 = 6"	3 = 3/8"-24 NF (straight threaded)	F43 0 TO 200°F	PC = Plastic Window
	090 = 9"	4 = 1/4" NPT	F47 0 TO 250°F	PB = Plain Bushing <small>(non-reset, for lab and test models only)</small>
HH = Model H (2-3/8" dial)	120 = 12"	6 = 1/8" NPT	F63 50 TO 300°F	
	150 = 15"	7 = 3/8" NPT	F67 50 TO 500°F	
Lab & Test Models		8 = Hex Reset Bushing	F81 150 TO 750°F	
QP = Model QP (1-1/4" dial) 5" Stem	180 = 18"		F85 200 TO 1000°F	
	240 = 24"		Celsius Ranges	
GL = Model GL (1-3/4" dial) 8" Stem	300 = 30"		C23 -40 TO 70°C	
	360 = 36"		C55** 0 TO 50°C	
	<small>-Intermediate lengths available up to 80"</small>		C43 0 TO 100°C	
	<small>-specify length in inches + tenths</small>		C53 -10 TO 100°C	
			C59 0 TO 150°C	
			C65 0 TO 200°C	
			C69 0 TO 300°C	
			C73 0 TO 400°F	
HL = Model HL (2-3/8" dial) 8" Stem			Dual F/C Ranges	
			D23** -40 TO 160°F & -40 TO 70°C	
			D55** 25 TO 125°F & 0 TO 50°C	
			D43 0 TO 200°F & 0 TO 100°C	
			D47** 0 TO 250°F & -20 TO 120°C	
			D63** 0 TO 300°F & 0 TO 150°C	
			D67 50 TO 500°F & 0 TO 250°C	
			D85 200 TO 1000°F & 100 TO 500°C	
			<small>* - 4" minimum stem length</small>	
			<small>** - Not available in Model Q.</small>	
		<small>*-Other sizes available</small>		

REOTEMP INSTRUMENT CORPORATION

Telephone: (800) 648-7737 FAX (858) 784-0720 • sales@reotemp.com • www.reotemp.com