

- Protects and isolates instrumentation
- Full 360° pressure reading
- Self-cleaning, flexing action
- Won't clog like traditional diaphragm seals
- Excellent pump protection



Materials of Construction

- Body (non-wetted) available in Carbon Steel or 316 Stainless Steel
- ANSI B16.5 Class 150 Flanges in Carbon Steel, 316 Stainless Steel, PVC, or Teflon® Coated Carbon Steel
- Sleeves available in Pure Gum Rubber, Neoprene, Chlorobutyl, Buna-N, Hypalon®, Viton®, EPDM, White Food-Grade Elastomers, Teflon®-coated Buna-N or Teflon®-coated Viton®
- Fill fluid: Silicone Oil (400°F), Ethylene Glycol & Water (200°F), Vegetable Oil (230°F)

Red Valve's Series 40 and Series 42 Pressure Sensors are the industry standards for protecting instrumentation, and assuring accurate, dependable pressure measurement of slurry and corrosive fluids.

The line pressure is sensed 360° through the flexible rubber sleeve. The captive fluid is displaced through the pressure sensor body to the instrument's Bourdon tube. All instruments are isolated and protected from the process, assuring positive and accurate readings.

The full-faced, thru-bolted Series 40 installs directly in-line. Costly installation and maintenance of pipe stands and saddle welds, which are required when installing antiquated diaphragm seals, are eliminated.

The thru-bolted Series 40 can be mounted in any flow direction, submerged in a tank, or mounted with a blind flange as a dead end to monitor tank levels.

The Red Valve standard gauge is bottom mounted, with a 2 1/2" diameter steel case; accuracy of this gauge is ±1% of the gauge reading. A 0-100 psi gauge is furnished as standard unless otherwise specified. 0-200 psi gauges are optional at no additional cost. All Red Valve Pressure Sensors and gauges are tested and calibrated through the mid-range to assure the highest level of accuracy. Pressure gauges, transmitters, transducers, recorders, differential pressure or vacuum switches are factory filled and mounted to the Series 40.

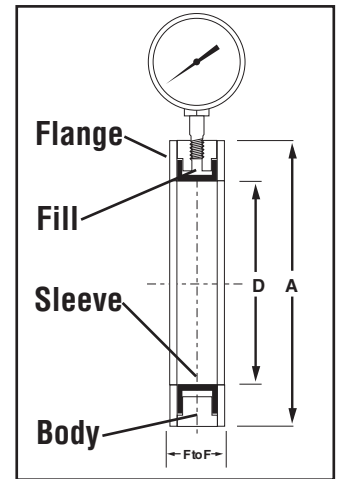

Dimensions Series 40

Size D	Outside Diameter A	Length F to F	100°F Working Pressure (psi)*	Weight (lbs)
1"	4 1/2"	1 7/8"	275	6
1 1/2"	5"	1 7/8"	275	8
2"	6"	1 7/8"	275	12
2 1/2"	7"	1 7/8"	275	16
3"	7 1/2"	1 7/8"	275	18
4"	9"	2 1/8"	275	27
5"	10"	2 1/4"	275	32
6"	11"	2 1/4"	275	37
8"	13 1/2"	2 1/2"	275	58

*Higher working pressures available. PVC unit has a working pressure of 200 psi

Contact REOTEMP for sizes 10" through 36"